

# COLOrband PiX™

## Quick Reference Guide

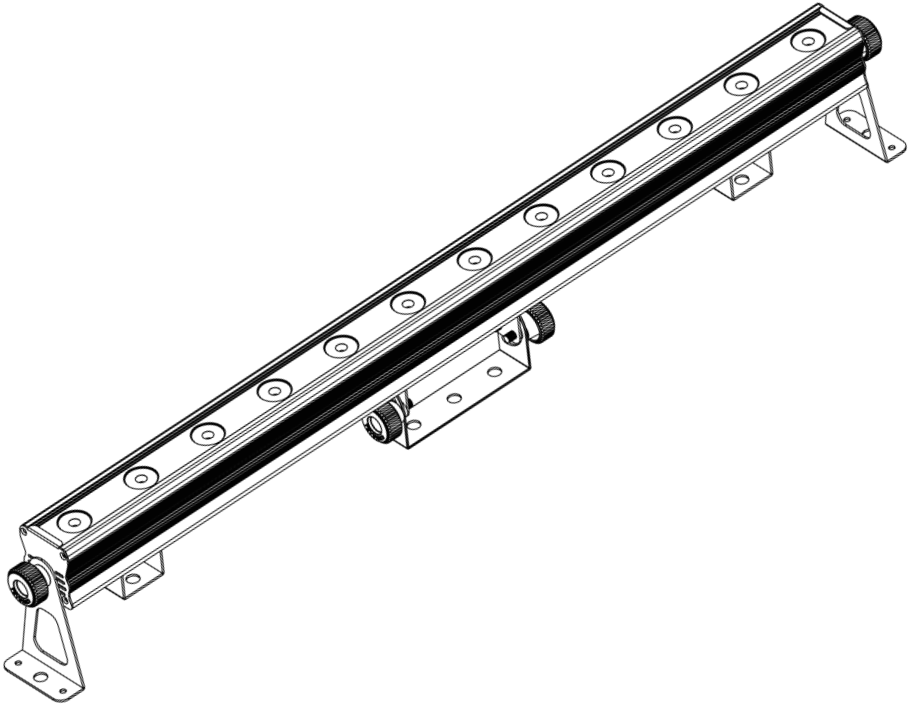

**CHAUVET**<sup>®</sup>

Value · Innovation · Performance

*It's Green Thinking*

## About This Guide

The COLORband PiX™ Quick Reference Guide (QRG) contains the product's connection and mounting information, as well as the menu options and the DMX values.

## Disclaimer

- Refer to this product's User Manual for detailed information and instructions. You can download the User Manual from the CHAUVET® website: [www.chauvetlighting.com](http://www.chauvetlighting.com).
- Read ALL the disclaimers and Safety Notes in this document as well as those in the product's User Manual before installing, operating, or maintaining this product.

## Safety Notes

These Safety Notes include important safety information about installation, usage, and maintenance.



- Always connect this product to a grounded circuit to avoid the risk of electrocution.
- Always disconnect from the power source before cleaning this product or replacing the fuse.
- Avoid direct eye exposure to the light source while the product is on.
- Make sure the power cord is not crimped or damaged.
- If mounting this product overhead, always secure it to a fastening device using a safety cable.
- Make sure there are no flammable materials close to the unit while operating.
- Do not touch this product's housing when operating because it may be very hot.



- Always make sure that the voltage of the outlet to which you are connecting this product is within the range stated on the decal or rear panel of the product.
- This product is for indoor use only! (IP20) To prevent risk of fire or shock, do not expose this product to rain or moisture.
- Always install this product in a location with adequate ventilation, at least 20 in (50 cm) from adjacent surfaces.
- Be sure that no ventilation slots on the unit's housing are blocked.
- Never connect this product to a dimmer.
- Make sure to replace the fuse with the same type and rating.
- Never carry this product from the power cord or any moving part. Always use the hanging/mounting bracket or the handles.
- The maximum ambient temperature is 104° F (40° C). Do not operate this product at higher temperatures.
- In the event of a serious operating problem, stop using the unit immediately.
- Never try to repair this product. Repairs performed by unauthorized technicians can lead to damage or malfunction. Please contact the nearest authorized technical assistance center.

**What Is Included**

- One COLORband PiX™
- One Power Cord
- Two L-Brackets
- One Warranty Card
- One Quick Reference Guide

**Before You Begin**

Prior to using your COLORband PiX™, ensure that you have received all parts indicated above in good condition. If the container or material inside appear damaged or show signs of mishandling, notify the carrier immediately, not CHAUVET®.

**Product Description**

The COLORband PiX™ is a full sized LED strip light with individual pixel control for pixel mapping effects. It includes multiple DMX personalities to fit any programming style. The COLORband PiX™ also includes high frequency LED dimming, allowing for flicker-free video operation.

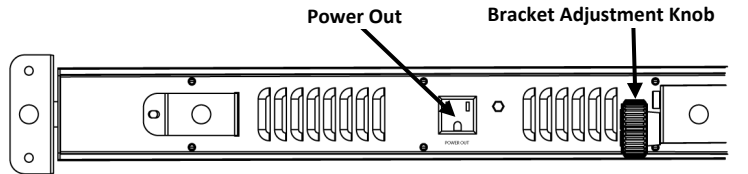

**Product Overview**

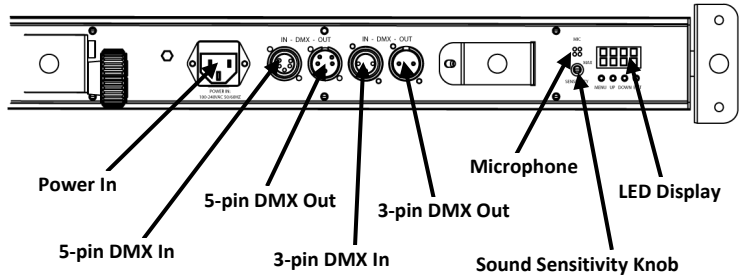

**AC Power** This product has an auto-ranging power supply that can work with an input voltage range of 100~240 VAC, 50/60 Hz.

**Power Linking** You can link up to 11 COLORband PiX™ units at 120 VAC and 20 units at 230 VAC. You should never exceed this number.

**Fuse Replacement** To replace the fuse in the COLORband PiX™, use the following steps:

1. Disconnect this product from the power outlet.
2. Wedge the tip of a flat head screwdriver into the slot of the fuse holder.
3. Pry the safety cap out of the housing pulling out the installed fuse.
4. Remove the blown fuse from the safety cap and replace with a fuse of the exact same type and rating.
5. Insert the fuse holder back in place and reconnect power.

**Programming** For details on how to program this product, please refer to the product's User Manual.

Control Panel Description	Button	Function
	<MENU>	Exits from the current menu or function.
	<UP>	Navigates upwards through the menu list and increases the numeric value when in a function.
	<DOWN>	Navigates downwards through the menu list and decreases the numeric value when in a function.
	<ENTER>	Enables the currently displayed menu or sets the currently selected value into the selected function.

## Menu Options

Main Level	Programming Levels		Description
Static Colors	C--	C1	Red
		C2	Green
		C3	Blue
		C4	Cyan
		C5	Magenta
		C6	Yellow
		C7	White
Auto Programs	P--	P1	7 Color Switching
		P2	7 Color Fading
		P3	3 Color Switching
		P4	3 Color Fading
		P5	Chase Program
		P6	7 Color Sound Active
		P7	7 Color Sound Active Chase + Strobe
Program Speed	S--	S001-S100	Selects auto program speed
Slave Mode	SLA		Sets Slave Mode
Custom Color Mixing	U--	r--	Red
		g--	Green
		b--	Blue
3-Channel Mode	3-CH	d001-d512	Selects DMX starting address
4-Channel Mode	4-CH		
6-Channel Mode	6-CH		
7-Channel Mode	7-CH		
9-Channel Mode	9-CH		
12-Channel Mode	12-CH		
18-Channel Mode	18-CH		
36-Channel Mode	36-CH		

- DMX Linking** The COLORband PiX™ can work with a DMX controller when linked using a regular DMX serial connection.  
If you are not familiar with the DMX standard, please download the *DMX Primer* document from [www.chauvetlighting.com](http://www.chauvetlighting.com).
- DMX Connection** The COLORband PiX™ uses a regular DMX data connection for its DMX personalities.  
Download the *COLORband PiX™ User Manual*. Refer to the *Setup* chapter to learn how to connect this product for DMX operation. To learn how to configure this product for DMX operation, refer to the *Operation* chapter.
- Start Address** To ensure full access to all channels in each DMX mode, the highest recommended DMX address is based on the channel mode. For example, if using the 36-channel mode on the COLORband PiX™, the highest channel you can use is **477**.
- Master/Slave Connection** The COLORband PiX™ uses the DMX data connection for its Master/Slave mode.  
Download the *COLORband PiX™ User Manual*. Refer to the *Setup* chapter to learn how to connect this product for Master/Slave operation. To learn how to configure this product for Master/Slave operation, refer to the *Operation* chapter.

## DMX Values

7-CH	Channel	Function	Value	Percent/Setting
	1	Red	000 ⇔ 255	0~100%
	2	Green	000 ⇔ 255	0~100%
	3	Blue	000 ⇔ 255	0~100%
	4	Color Macros	000 ⇔ 015	No function
			016 ⇔ 255	Color Macros
	5	Speed	000 ⇔ 255	Speed (slow to fast) (when CH.6 is between 032-223)
		Strobe (CH.1-CH.4 only)	000 ⇔ 015	No function
			016 ⇔ 255	0-30Hz
	6	RGB Mode	000 ⇔ 031	No function
			032 ⇔ 063	Pulse effect 0%-100%
			064 ⇔ 095	Pulse effect 100%-0%
			096 ⇔ 114	Pulse effect 100%-0%-100%
			115 ⇔ 127	Chase program
			128 ⇔ 159	Auto fade transition
			160 ⇔ 191	Auto snap transition (3 colors)
		192 ⇔ 223	Auto snap transition (7 colors)	
		224 ⇔ 255	Sound active mode	
	7	Dimmer	000 ⇔ 255	0~100%

3-CH	Channel	Function	Value	Percent/Setting
	1	Red	000 ⇔ 255	0~100%
	2	Green	000 ⇔ 255	0~100%
	3	Blue	000 ⇔ 255	0~100%

4-CH	Channel	Function	Value	Percent/Setting
	1	Red	000 ⇔ 255	0~100%
	2	Green	000 ⇔ 255	0~100%
	3	Blue	000 ⇔ 255	0~100%
	4	Dimmer	000 ⇔ 255	0~100%

6-CH	Channel	Function	Value	Percent/Setting	Section
	1	Red	000 ⇄ 255	0~100%	1
	2	Green	000 ⇄ 255	0~100%	
	3	Blue	000 ⇄ 255	0~100%	
	4	Red	000 ⇄ 255	0~100%	2
	5	Green	000 ⇄ 255	0~100%	
	6	Blue	000 ⇄ 255	0~100%	

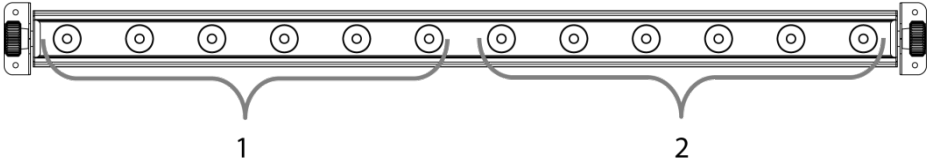

9-CH	Channel	Function	Value	Percent/Setting	Section
	1	Red	000 ⇄ 255	0~100%	1
	2	Green	000 ⇄ 255	0~100%	
	3	Blue	000 ⇄ 255	0~100%	
	4	Red	000 ⇄ 255	0~100%	2
	5	Green	000 ⇄ 255	0~100%	
	6	Blue	000 ⇄ 255	0~100%	
	7	Red	000 ⇄ 255	0~100%	3
	8	Green	000 ⇄ 255	0~100%	
	9	Blue	000 ⇄ 255	0~100%	

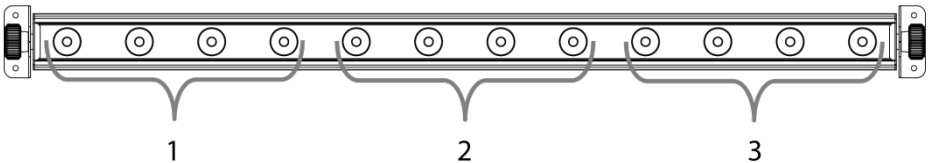



12-CH	Channel	Function	Value	Percent/Setting	Section
	1	Red	000 ⇔ 255	0~100%	1
	2	Green	000 ⇔ 255	0~100%	
	3	Blue	000 ⇔ 255	0~100%	
	4	Red	000 ⇔ 255	0~100%	2
	5	Green	000 ⇔ 255	0~100%	
	6	Blue	000 ⇔ 255	0~100%	
	7	Red	000 ⇔ 255	0~100%	3
	8	Green	000 ⇔ 255	0~100%	
	9	Blue	000 ⇔ 255	0~100%	
	10	Red	000 ⇔ 255	0~100%	4
	11	Green	000 ⇔ 255	0~100%	
	12	Blue	000 ⇔ 255	0~100%	

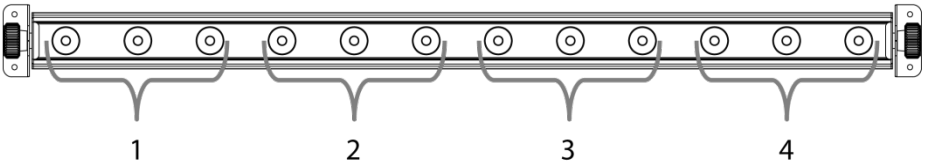

18-CH	Channel	Function	Value	Percent/Setting	Section
	1	Red	000 ⇔ 255	0~100%	1
	2	Green	000 ⇔ 255	0~100%	
	3	Blue	000 ⇔ 255	0~100%	
	4	Red	000 ⇔ 255	0~100%	2
	5	Green	000 ⇔ 255	0~100%	
	6	Blue	000 ⇔ 255	0~100%	
	7	Red	000 ⇔ 255	0~100%	3
	8	Green	000 ⇔ 255	0~100%	
	9	Blue	000 ⇔ 255	0~100%	
	10	Red	000 ⇔ 255	0~100%	4
	11	Green	000 ⇔ 255	0~100%	
	12	Blue	000 ⇔ 255	0~100%	
	13	Red	000 ⇔ 255	0~100%	5
	14	Green	000 ⇔ 255	0~100%	
	15	Blue	000 ⇔ 255	0~100%	
	16	Red	000 ⇔ 255	0~100%	6
	17	Green	000 ⇔ 255	0~100%	
	18	Blue	000 ⇔ 255	0~100%	

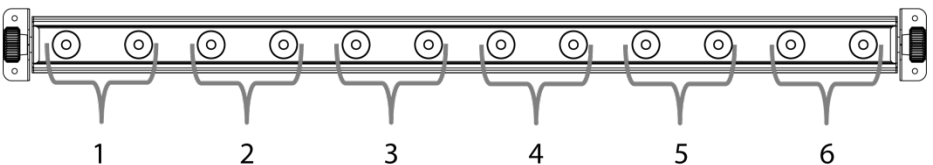

36-CH	Channel	Function	Value	Percent/Setting	Section
	1	Red	000 ⇄ 255	0~100%	1
	2	Green	000 ⇄ 255	0~100%	
	3	Blue	000 ⇄ 255	0~100%	
	4	Red	000 ⇄ 255	0~100%	2
	5	Green	000 ⇄ 255	0~100%	
	6	Blue	000 ⇄ 255	0~100%	
	7	Red	000 ⇄ 255	0~100%	3
	8	Green	000 ⇄ 255	0~100%	
	9	Blue	000 ⇄ 255	0~100%	
	10	Red	000 ⇄ 255	0~100%	4
	11	Green	000 ⇄ 255	0~100%	
	12	Blue	000 ⇄ 255	0~100%	
	13	Red	000 ⇄ 255	0~100%	5
	14	Green	000 ⇄ 255	0~100%	
	15	Blue	000 ⇄ 255	0~100%	
	16	Red	000 ⇄ 255	0~100%	6
	17	Green	000 ⇄ 255	0~100%	
	18	Blue	000 ⇄ 255	0~100%	
	19	Red	000 ⇄ 255	0~100%	7
	20	Green	000 ⇄ 255	0~100%	
	21	Blue	000 ⇄ 255	0~100%	
	22	Red	000 ⇄ 255	0~100%	8
	23	Green	000 ⇄ 255	0~100%	
	24	Blue	000 ⇄ 255	0~100%	
	25	Red	000 ⇄ 255	0~100%	9
	26	Green	000 ⇄ 255	0~100%	
	27	Blue	000 ⇄ 255	0~100%	
	28	Red	000 ⇄ 255	0~100%	10
	29	Green	000 ⇄ 255	0~100%	
	30	Blue	000 ⇄ 255	0~100%	
	31	Red	000 ⇄ 255	0~100%	11
	32	Green	000 ⇄ 255	0~100%	
	33	Blue	000 ⇄ 255	0~100%	
	34	Red	000 ⇄ 255	0~100%	12
	35	Green	000 ⇄ 255	0~100%	
	36	Blue	000 ⇄ 255	0~100%	

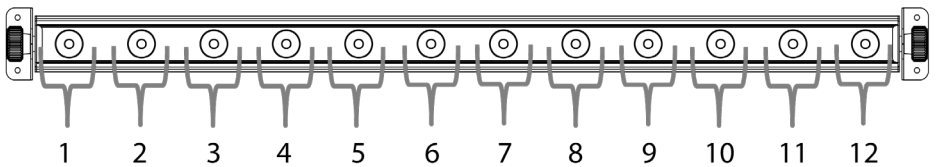

**Mounting** Before mounting this product, read the Safety Notes at the beginning of this guide and in the product's User Manual. The mounting instructions are provided in the *Setup* chapter of the User Manual.

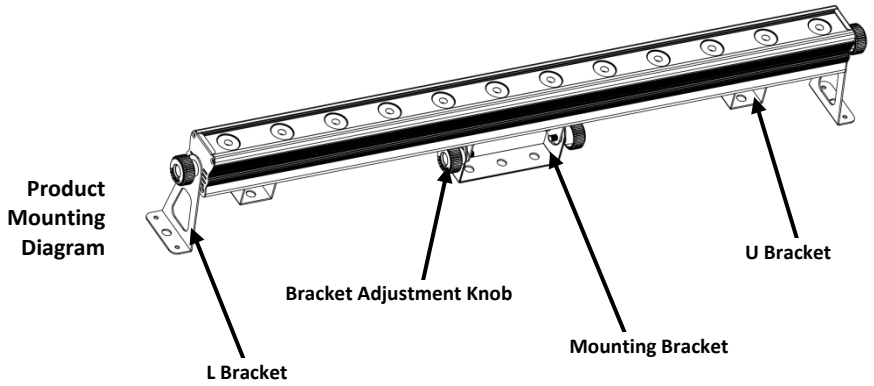

**Contact Us**

**World Headquarters**

CHAUVET®

**General Information**

Address: 5200 NW 108th Avenue  
Sunrise, FL 33351  
Voice: (954) 929-1115  
Fax: (954) 929-5560  
Toll free: (800) 762-1084

**Technical Support**

Voice: (954) 929-1115 (Press 4)  
Fax: (954) 756-8015  
Email: [tech@chauvetlighting.com](mailto:tech@chauvetlighting.com)

**World Wide Web**

[www.chauvetlighting.com](http://www.chauvetlighting.com)

**United Kingdom and Ireland**

CHAUVET® Europe Ltd.

**General Information**

Address: Unit 1C  
Brookhill Road Industrial Estate  
Pinxton, Nottingham, UK  
NG16 6NT  
Voice: +44 (0)1773 511115  
Fax: +44 (0)1773 511110

**Technical Support**

Email: [uktech@chauvetlighting.com](mailto:uktech@chauvetlighting.com)

**World Wide Web**

[www.chauvetlighting.co.uk](http://www.chauvetlighting.co.uk)

Outside the U.S., United Kingdom, or Ireland, contact your distributor of record. Follow their instructions to request support or to return a product. Visit our website for contact details.

**COLORband PiX™ QRG – Rev. 06**

**© Copyright 2012 CHAUVET®**

All rights reserved.

Printed in the P. R. C.



**UL 1573**

**CSA C22.2 No. 166**

**E113093**