

HURRICANETM **HAZE 3D**

User Manual

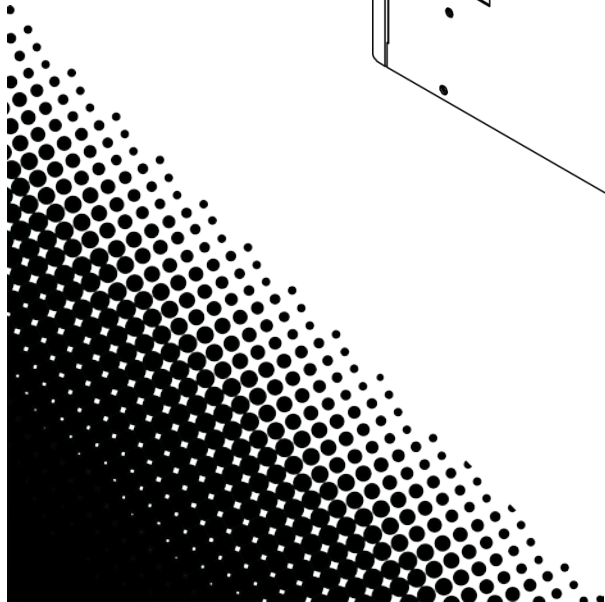
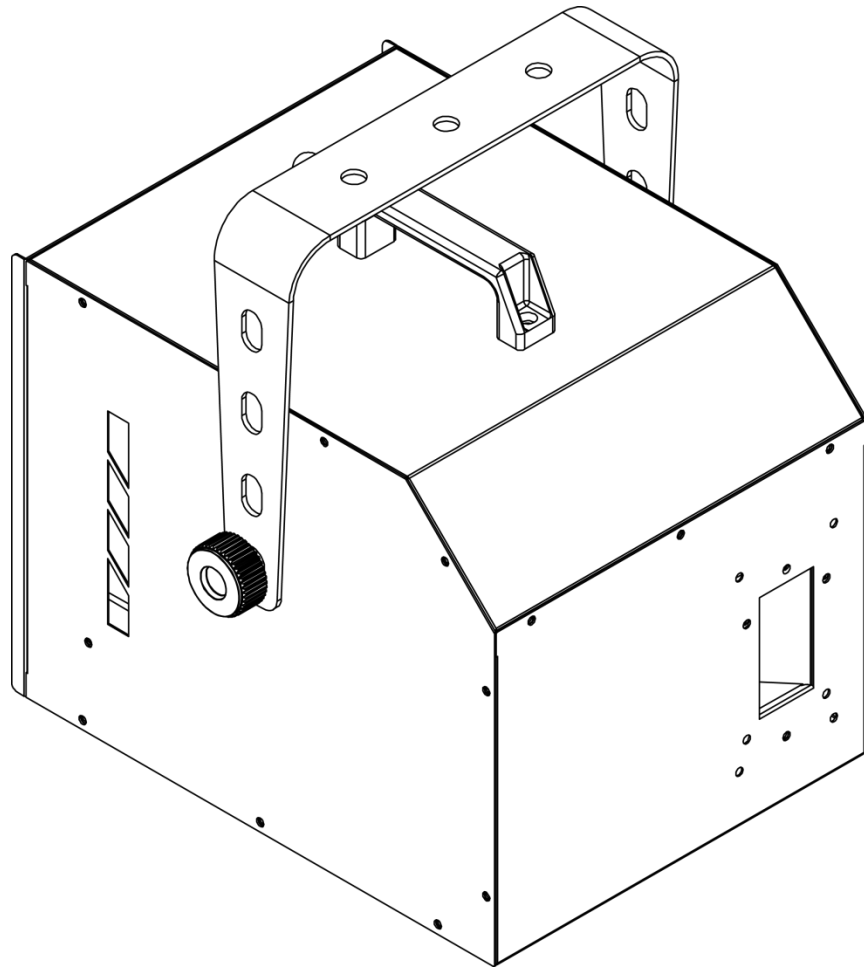

Table of Contents

Table of Contents	2
1. Before You Begin	3
What Is Included	3
Unpacking Instructions	3
Claims	3
Manual Conventions	3
Symbols	3
Document Information	3
Product at a Glance	4
Safety Notes	4
2. Introduction	5
Product Overview	5
Product Dimensions	6
3. Setup	7
AC Power	7
Fuse Replacement	7
Mounting	8
Orientation	8
Rigging	8
4. Operation	10
Control Panel Operation	10
Fluid Tank Indicator LEDs	10
Menu Map	10
HC-T Wired Timer Remote Operation	11
Configuration (Standalone Mode)	12
Manual Mode	12
Configuration (DMX)	12
Starting Address	12
DMX Channel Assignments and Values	12
2-CH	12
5. Technical Information	13
General Maintenance	13
Storage	13
General Troubleshooting	14
6. Technical Specifications	15
Returns	16
Contact Us	16

1. Before You Begin

What Is Included

- Hurricane™ Haze 3D
- Power Cord
- HC-T Wired Timer Remote (15 ft length)
- Warranty Card
- Quick Reference Guide
- Hanging Bracket with Mounting Hardware

Unpacking Instructions

Immediately upon receiving this product, carefully unpack it and check the container in which you received it.

Claims



If the container or the material inside the container (the product and included accessories) appear damaged from shipping, or show signs of mishandling, upon receipt notify the carrier immediately, not Chauvet. Failure to do so in a timely manner may invalidate your claim with the carrier. In addition, keep the container and all the packing material for inspection.

For other issues such as missing components or parts, damage not related to shipping, or concealed damage, file a claim with Chauvet within seven (7) days of receiving the merchandise.

Manual Conventions

Convention	Meaning
<Menu>	A key to be pressed on the product's control panel
1-512	A range of values
50/60	A set of values of which only one can be chosen
Settings	A menu option not to be modified (for example, showing the operating mode/current status)
Menu > Settings	A sequence of menu options to be followed
ON	A value to be entered or selected

Symbols

Convention	Meaning
	Critical installation, configuration, or operation information. Failure to comply with this information may render the product partially or completely inoperative, cause damage to the product, or cause harm to the user.
	Important installation or configuration information. Failure to comply with this information may prevent the product from functioning correctly.
	Useful information.

Document Information

The information and specifications contained in this document are subject to change without notice. Chauvet assumes no responsibility or liability for any errors or omissions that may appear in this manual.

© Copyright 2014 Chauvet. All rights reserved.

Electronically published by Chauvet in the United States of America.

Author	Date	Editor	Date
A. Leon	10/30/14	M. Trouard	10/30/14

Product at a Glance

Use on Dimmer	X	Auto Programs	X
Outdoor Use	X	Auto-ranging Power Supply	X
Sound-Activated	X	Replaceable Fuse	P
DMX	P	User-Serviceable	X
Master/Slave	X		

Safety Notes



Please read the following Safety Notes carefully before working with the product. The Notes include important safety information about installation, usage, and maintenance.

- Not intended for permanent installations.
- Always connect the product to a grounded circuit to avoid the risk of electrocution.
- Always disconnect this product from the power source before cleaning it or replacing the fuse.
- Make sure the power cord is not crimped or damaged.
- Never disconnect the power cord by pulling or tugging on the cord.
- Do not touch the output nozzle on this product. It is very hot during operation and it may remain hot for several hours after turning the unit off.
- If mounting this product overhead, always secure it to a fastening device using a safety cable.
- Do not mount this product on a flammable surface (e.g., wood, linoleum, carton, plastic, or carpet).
- Do not drink the haze fluid. If you do, call your local emergency service (911 in the US) for help.
- Do not add perfume, alcohol, gasoline, or any other flammables to the haze fluid.
- Always make sure that the voltage of the outlet to which you are connecting the product is within the range stated in the decal or rear panel of the product.
- Keep this User Manual for future consultation. If you sell this product to another user, be sure that they also receive this document.
- This product is for indoor use only! To prevent risk of fire or shock, do not expose this product to rain or moisture.
- Make sure there are no flammable materials close to the unit while operating
- Always install this product in a location with adequate ventilation, at least 20 in (50 cm) from adjacent surfaces.
- Be sure that no ventilation slots on the unit's housing are blocked.
- Make sure to replace the fuse with another of the same type and rating.
- The maximum ambient temperature (Ta) is 104 °F (40 °C). Do not operate this product at higher temperatures.
- In the event of a serious operating problem, stop using the unit immediately.
- Never try to repair this product. Repairs carried out by unskilled people can lead to damage or malfunction. Please contact the nearest authorized technical assistance center.
- Never connect this product to a dimmer or rheostat.
- Depending on the amount of haze generated, all haze machines may set off smoke detectors.
- In certain environment, haze fluid-based machines may leave a slippery residue on floors and surfaces.
- Do not use for space heating purposes.
- Use only CHAUVET® DJ water-based haze fluid.
- Drain the tank before transporting the product.
- To eliminate unnecessary wear and improve its lifespan, during periods of non-use completely disconnect the product from power via breaker or by unplugging it.



FCQ (Fog Cleaner Quart) was specifically developed by Chauvet to clean your Hurricane™ Haze 3D. Make sure you use FCQ regularly, no longer than 90 days between cleanings, to increase the life of your product.

2. Introduction

Product Overview

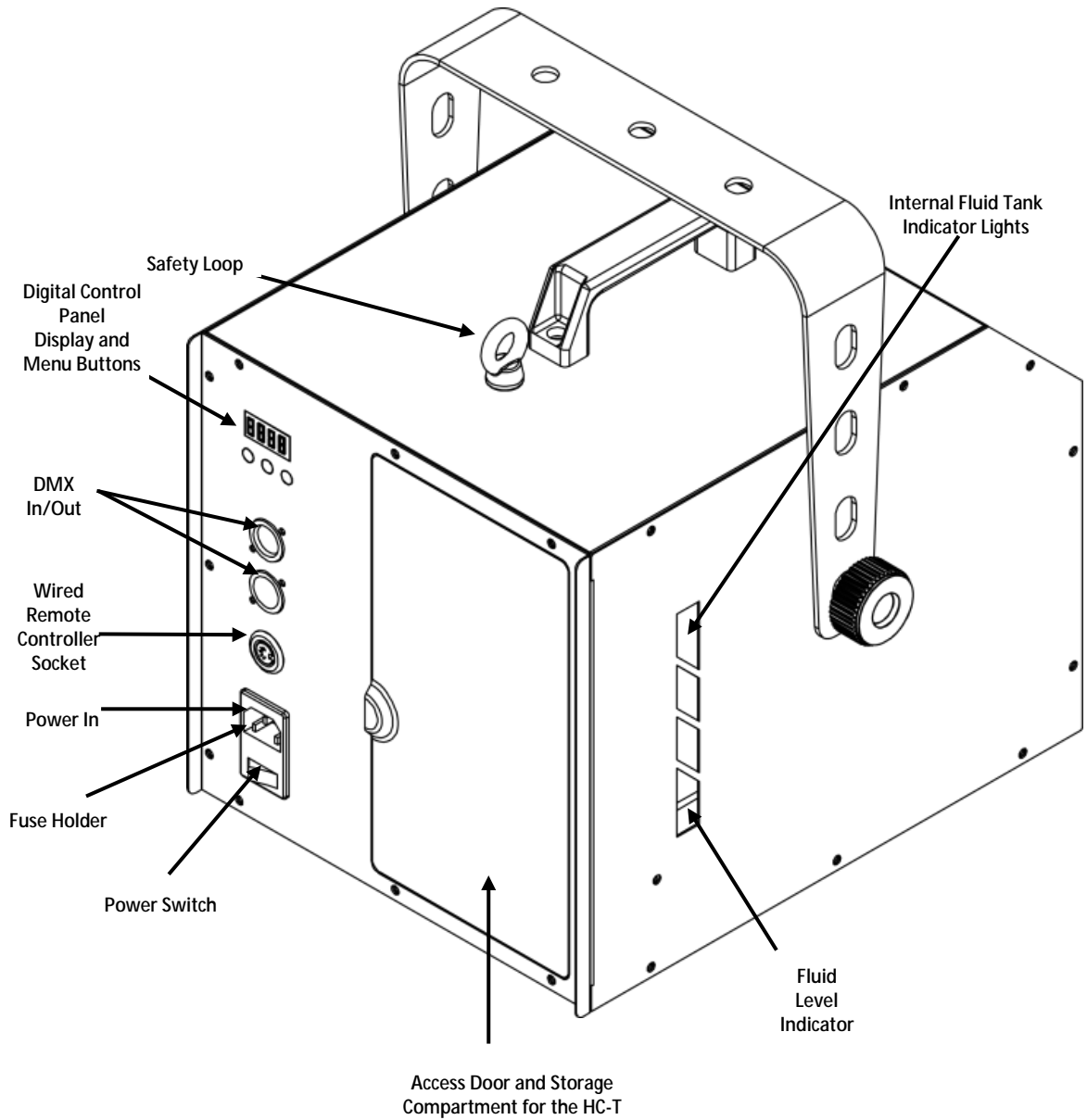

Product Dimensions

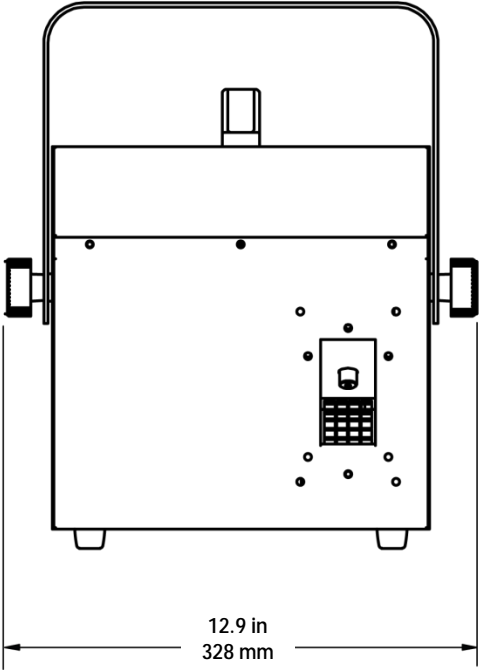
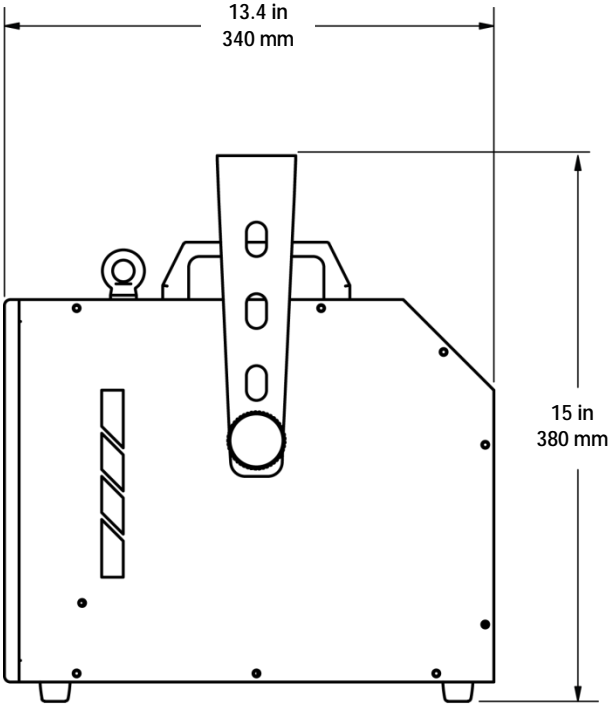

3. Setup

AC Power

This product can work with an input voltage of either 120 VAC, 60 Hz or 230 VAC, 50 Hz depending on the model.

To determine the power requirements for a particular product, see the label affixed to the back plate of the product or refer to the product's specifications chart. The listed current rating indicates the product's average current draw under normal conditions.



Always connect this product to a protected circuit (circuit breaker or fuse), making sure that it has an appropriate electrical ground to avoid the risk of electrocution or fire.



Never connect this product to a rheostat (variable resistor) or dimmer circuit, even if the rheostat or dimmer channel serves only as a 0 to 100% switch.

Fuse Replacement



Disconnect this product from the power outlet before replacing the fuse.

1. Disconnect the product from power.
2. Wedge the tip of a flat-head screwdriver into the slot of the fuse holder.
3. Pry the fuse out of the housing.
4. Remove the blown fuse from the holder and replace with a fuse of the exact same type and rating.
5. Insert the fuse holder back in place and reconnect power.

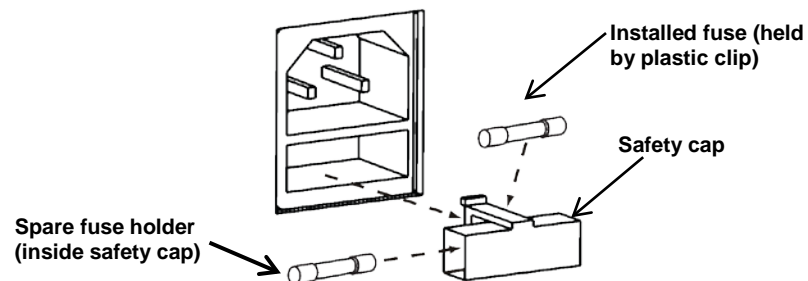

The product does not ship with a spare fuse; however, the safety cap has room for a spare.

Mounting

Orientation The Hurricane™ Haze 3D may not be tilted. This product should be mounted, placed on the ground, or on any oblique surface at a less than 15° angle to avoid the risk of the haze fluid tank leaking. Be sure there is adequate room for ventilation and programming.

Rigging Be sure that the structure or surface onto which you are mounting this product can support its weight. Please see the [Technical Specifications](#) section of this manual for weight information.

Make sure to mount the product securely to a rigging point, whether an elevated platform or a truss.

When rigging this product onto a truss, you should use a mounting clamp of appropriate weight capacity. The bracket has a 13 mm hole, which is appropriate for this purpose.

When mounting this product overhead, always use a safety cable. Never mount directly above people as condensation may drip and fluid may be hot.

Before deciding on a location for this product, always make sure that it will be easy to access the unit for maintenance and programming purposes.

When power linking multiple products, you must always consider the length of the power linking cable and mount the products close enough for the cable to reach them.

Only loosen or tighten the bracket knobs using your bare hands. Using tools could damage the knobs.

Mounting Diagram

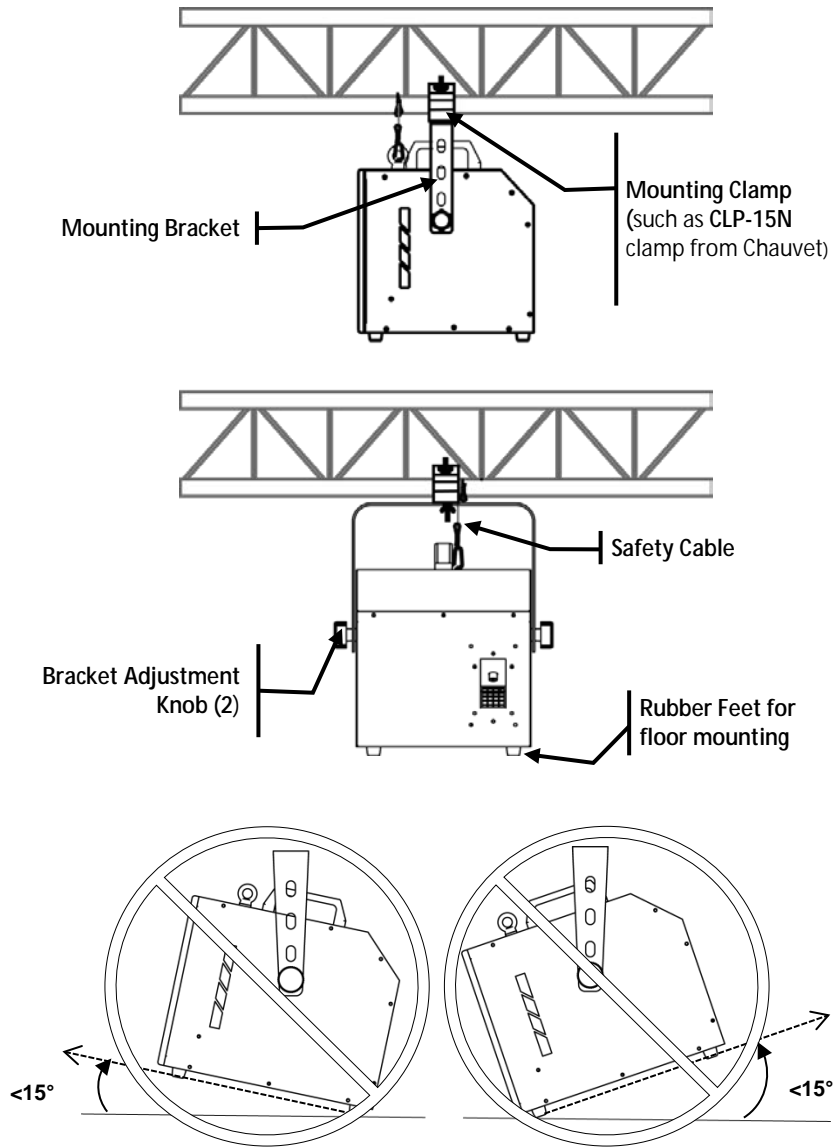

4. Operation

Control Panel Operation

To access the control board functions, use the three buttons located underneath the display.

Button	Function
<MENU>	Press to scroll through the operating modes
<▲> UP	Press to find a higher value
<▼> DOWN	Press to find a lower value

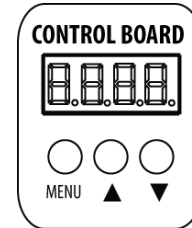

Important note regarding the priority level for the three types of methods used to control the operation of your Hurricane™ Haze 3D.

The priority control levels are:

1. **DMX** - A DMX controller takes priority control over both the product's digital control panel and the HC-T.
2. **Digital control panel** - The control panel will only take priority control over the HC-T.
3. **HC-T remote controller** - The HC-T has the lowest priority control level.



Examples:

- If using the digital control panel and afterwards you connect a DMX controller to the product, then the DMX controller will take priority control.
- If using the remote controller and the digital control panel is used next, then the digital control panel will take priority control.

Fluid Tank Indicator LEDs

Indicator LEDs show the status of the fill tank, as follows:

- Red - the heater is currently warming up
- Flashing Red - the heater is currently warming up and requires refilling
- Blue - the hazer is ready
- Flashing Blue - the heater is warmed but the fluid tank requires refilling

Note: The Hurricane™ Haze 3D may be operational while the heater is warming up.



See the [General Troubleshooting](#) section to identify possible sources of trouble and find solutions.

Menu Map

Mode	Programming Steps		Description
DMX Mode	d***	001–512	Selects the DMX starting address
Manual Mode	Haze Volume	h001–h005	Selects the volume of haze output, low to high
	Blower Speed	f001–f005	Selects the blower fan speed, low to high

HC-T Wired Timer Remote Operation

The HC-T wired timer controller allows you to automatically trigger haze output by setting interval and duration times. LED indicator lights display the machine and controller's current state. Rotary knobs set interval and duration times, while manual and continuous buttons allow overriding control.



Using the Control Panel, set the Haze Volume and Blower Speed output to x000 prior to connecting the HC-T. You can then connect and operate the HC-T with the Hurricane™ Haze 3D.

1. Connect the Hurricane™ Haze 3D to power and turn the power switch to the on position.
2. Plug the HC-T timer controller into the wired remote controller socket on the back of the haze machine.
3. Press the **<TIMER ON/OFF>** latching button on the HC-T. The Timer LED Indicator above the button will light up. The **<TIMER ON/OFF>** latching button will remain on until it is pressed again.
4. Set the INTERVAL, DURATION, and OUTPUT adjustment knobs to the desired positions.
 - INTERVAL knob sets the amount of time in between bursts of haze.
 - DURATION knob sets the length of time that the haze machine will run during the burst.
 - OUTPUT knob adjusts the haze output.
5. Press the **<CONTINUOUS>** latching button and the haze machine outputs haze until the button is pressed again. The Manual/Power LED Indicator above the button will light up during continuous operation.

Note: The duration of continuous haze output is based on the capability of the haze machine.

6. Press the **<MANUAL>** button to momentarily output haze. The haze machine will output haze for as long as you hold down the button. During manual operation the Manual Momentary LED Indicator above the button will light up.

Note: The duration of manual haze output is based on the capability of the haze machine.



When using the manual button, it may take a few seconds for the hazer to respond because the fan is building up speed.

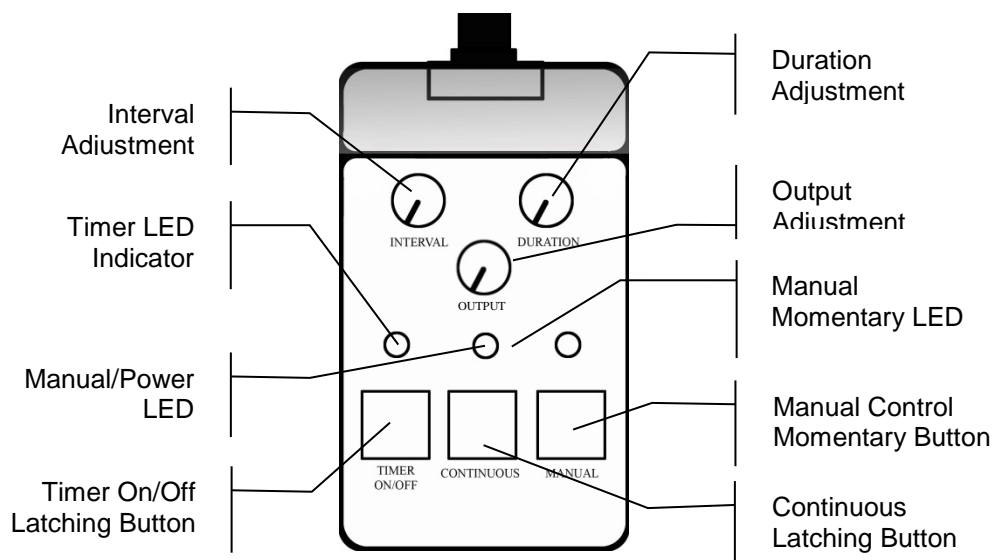

Configuration (Standalone Mode)

Set this product in one of the standalone modes to control it without a DMX controller.

1. Connect this product to a suitable power outlet.
2. Turn this product on.

Manual Mode



Never connect a product that is operating in any standalone mode, such as Manual mode, to a DMX string connected to a DMX controller. Products in standalone mode may transmit DMX signals that could interfere with the DMX signals from the controller.

To enable the Manual mode, follow the instructions below:

1. Press **<MENU>** repeatedly until **h***** shows on the display.
2. Use **<UP>** or **<DOWN>** to adjust the haze volume.
3. Press **<MENU>** repeatedly until **f***** shows on the display.
4. Use **<UP>** or **<DOWN>** to adjust the blower speed.

Configuration (DMX)

Set this product in DMX mode to control it with a DMX controller.

1. Connect this product to a suitable power outlet.
2. Turn this product on.
3. Connect a DMX cable from the DMX output of the DMX controller to the DMX input socket of this product.

Starting Address

The Hurricane™ Haze 3D has one DMX personality, a 2-channel mode for basic control.

The Hurricane™ Haze 3D uses up to two channels in its 2-channel DMX mode, which defines the highest configurable address to **511**.

When selecting a starting DMX address, always consider the number of DMX channels the DMX mode uses. If you choose a starting address that is too high, you could restrict the access to some of the product's channels.

If you are not familiar with the DMX protocol, download the DMX Primer from www.chauvetlighting.com.

To select the starting address, do the following:

1. Press **<MENU>** repeatedly until **d***** shows on the display.
2. Use **<UP>** or **<DOWN>** to select the starting address.

DMX Channel Assignments and Values 2-CH

Channel	Function	Value	Setting
1	Blower speed	000 ó 005	Off
		006 ó 075	Level 1
		076 ó 125	Level 2
		126 ó 165	Level 3
		166 ó 185	Level 4
		186 ó 255	Level 5
2	Haze volume	000 ó 038	Off
		039 ó 069	Level 1
		070 ó 101	Level 2
		102 ó 132	Level 3
		133 ó 187	Level 4
		188 ó 255	Level 5

5. Technical Information

Hazer Maintenance

Do not allow the haze machine to become clogged. After every 40 hours of continuous operation, use CHAUVET® Fog Cleaner Quart (FCQ) through the system to prevent the accumulation of particulate matter in the heating element.

The recommended cleaning procedure is as follows:

1. Unplug the product from power.
2. Empty all haze fluid from the machine.
3. Add cleaning solution to the tank.
4. Connect the product to power and allow it to warm up.
Run the unit in a well-ventilated area until the tank is almost empty. **Do not allow the pump to run dry.**
5. Refill with haze fluid to continue using the hazer. Run the machine briefly to clear any remaining cleaning solution from the pump and heater.

Note: Do not operate the machine without fluid at any time.



Do not operate the machine without fluid at any time.



Fog Cleaner Quart (FCQ) was specifically developed by Chauvet to clean your Hurricane™ Haze 3D. Make sure you use FCQ regularly, no longer than 90 days between cleanings, to increase the life of your product.

Storage

Before storing the hazer, run FCQ through the system as described in the cleaning procedure above; however, only follow steps 1 through 5. **Do not refill the tank with haze fluid if storing the hazer.** Cleaning the system prior to storage will help prevent any particles from condensing inside the pump or heater while not in use.



Test-run your Hurricane™ Haze 3D on a monthly basis to achieve the best performance.

General Troubleshooting

Symptom	Indicator Status	Possible Cause	Possible Action
No output or short output	Red	Heater warming up	Allow the product to warm up completely. This should take less than 10 minutes.
	Red flashing	Air bubble in fluid line	Allow the product to warm up completely.
			Turn fog machine 45° to flatten out the bubble and allow the fog fluid to flow properly
			Turn off the product for 5 seconds, and then turn it back on. Repeat as necessary. After more than 10 attempts, contact Customer Service.
	Blue	Incorrect fluid	Clean thoroughly with CHAUVET® FCQ. For full instructions, see Hazer Maintenance . Refill with CHAUVET® water-based haze fluid.
		Blocked pipes	Contact Customer Service
Failing part		Contact Customer Service	
Spitting fluid	Blue blinking	Incorrect fluid	Clean thoroughly with CHAUVET® FCQ. For full instructions, see Hazer Maintenance . Refill with CHAUVET® water-based haze fluid.
		Blocked pipes	Contact Customer Service
		Failing part	Contact Customer Service
	Blue	Incorrect fluid	Clean thoroughly with CHAUVET® FCQ. For full instructions, see Hazer Maintenance . Refill with CHAUVET® water-based haze fluid.
		Blocked pipes	Contact Customer Service
		Failing part	Contact Customer Service
Normal	Blue	Normal	Normal function
Circuit breaker or fuse keeps blowing	N/A	Excessive load on the circuit	Make sure that the total load does not exceed the recommended capacity of the breaker or fuse's nominal current
Product does not power up		Short circuit along the power lines	Check the power lines and power cords
		No energy on power outlet	Check power outlet Change to another outlet
		Loose or damaged power cord	Check the power cord
		Blown fuse	Replace blown fuse with a good one of the same type and rating
		Internal problem	Send product for repair
Product does not respond to DMX		Wrong starting address on the product	Set the correct starting address on the product
		Wrong polarity setting on the DMX controller	Change the signal polarity on the controller
		Loose or damaged DMX cable	Check the DMX cable entering the faulty unit
		Internal problem	Send product for repair
Intermittent DMX Problems	Blue	Signal cables are not DMX compatible	Replace non-DMX cables with true DMX cables
		Interference with AC or radio signals	Keep DMX cables away from AC wires or radio equipment
		DMX cable too long	Use a shorter DMX cable or install an optically coupled DMX amplifier right before the product with intermittent problems
		Terminator not connected	Install a terminator
False Sensor Reading (Priming)	Red	Air bubbles in fluid line	Fill the tank. Allow the unit to reach the normal operating temperature and for the blue indicator to light. Set the output to the highest level. Power cycle the unit 1-2 times until the fluid reaches the sensor. The blue tank indicator light stops flashing.
			Fill the tank. While the unit is operating, pinch the fluid line between your thumb and forefinger, and hold for 3 to 5 seconds creating a vacuum in the system. Release the pinched portion and allow the fluid to flow naturally.
	Red	Empty fluid tank	Refill tank with the correct CHAUVET® water-based haze fluid



If you still experience problems after trying the solutions presented here, contact Chauvet Technical Support.

6. Technical Specifications

Dimensions and Weight	Length	Width	Height	Weight
	13.4 in (340 mm)	12.9 in (328 mm)	15 in (380 mm)	23 lb (10.5 kg)

Note: Dimensions in inches, rounded to the nearest decimal digit.

Power	Power Supply Type	Range	Voltage Selection
	Model-specific	120 VAC, 60 Hz or 230 VAC, 50 Hz	Fixed voltage

Parameter	120 V, 60 Hz	230 V, 50 Hz
Consumption	1,300 W	1,462 W
Operating current	11 A	6.2 A
Fuse size	F 13 A, 250 V	F 7 A, 250 V

Power I/O	US/Canada	UK/Worldwide
Power input connector	IEC	IEC
Power cord plug	Edison	Local plug

Operation	Heat-up Time	Tank Capacity	Fluid Consumption
	4 min	0.7 gal (2.5 l)	14 ml/min

Misc.	Output
	1,700 cfm

Approved Fluids	CHAUVET® DJ Haze Fluid (Gallon)	
	High Performance Haze Fluid (HFG)	Premium Haze Fluid (PHF)

Thermal	Maximum External Temp.	Cooling System
	104 °F (40 °C)	Convection

DMX			
DMX	I/O Connectors	Connector Type	Channel Range
	3-pin XLR	Sockets	2

Ordering	Product Name	Item Code	UPC Number
	Hurricane™ Haze 3D	05070795 (120 V) 05070798 (230 V)	781462211431 781462211462



Returns

To return a product or request support:

- In the U.S., contact Chauvet World Headquarters.
- In the UK or Ireland, contact Chauvet Europe Ltd.
- In Mexico, contact Chauvet Mexico.
- In any other country, DO NOT contact Chauvet. Contact your distributor. See www.chauvetlighting.com for distributors outside the U.S., United Kingdom, Ireland, or Mexico.



If you live outside the U.S., United Kingdom, Ireland, or Mexico, contact your distributor of record and follow their instructions on how to return Chauvet products to them. Visit our website for contact details.

Call the corresponding Chauvet Technical Support office and request a Return Merchandise Authorization (RMA) number before shipping the product. Be prepared to provide the model number, serial number, and a brief description of the cause for the return.

You must send the merchandise prepaid, in its original box, and with its original packing and accessories. Chauvet will not issue call tags.

Clearly label the package with the RMA number. Chauvet will refuse any product returned without an RMA number.



Write the RMA number on a properly affixed label. DO NOT write the RMA number directly on the box.

Before sending the product, clearly write the following information on a piece of paper and place it inside the box:

- Your name
- Your address
- Your phone number
- RMA number
- A brief description of the problem

Be sure to pack the product properly. Any shipping damage resulting from inadequate packaging will be your responsibility. FedEx packing or double-boxing is recommended.



Chauvet reserves the right to use its own discretion to repair or replace returned product(s).

Contact Us

WORLD HEADQUARTERS - Chauvet

General Information

Address: 5200 NW 108th Avenue
Sunrise, FL 33351
Voice: (954) 577-4455
Fax: (954) 929-5560
Toll free: (800) 762-1084

Technical Support

Voice: (954) 577-4455 (Press 4)
Fax: (954) 756-8015
Email: tech@chauvetlighting.com

World Wide Web www.chauvetlighting.com

UNITED KINGDOM AND IRELAND - Chauvet Europe Ltd.

General Information

Address: Unit 1C
Brookhill Road Industrial Estate
Pinxton, Nottingham, UK
NG16 6NT
Voice: +44 (0)1773 511115
Fax: +44 (0)1773 511110

Technical Support

Email: uktech@chauvetlighting.com

World Wide Web www.chauvetlighting.co.uk

MEXICO - Chauvet Mexico

General Information

Address: Av. Santa Ana 30
Parque Industrial Lerma
Lerma, Mexico C.P. 52000
Voice: +52 (728) 285-5000

Technical Support

Email: servicio@chauvet.com.mx

World Wide Web www.chauvet.com.mx

Outside the U.S., United Kingdom, Ireland, or Mexico, contact your dealer. Follow their instructions to request support or to return a product. Visit our website for contact details.