

Slim**PAR**TM **38**

User Manual

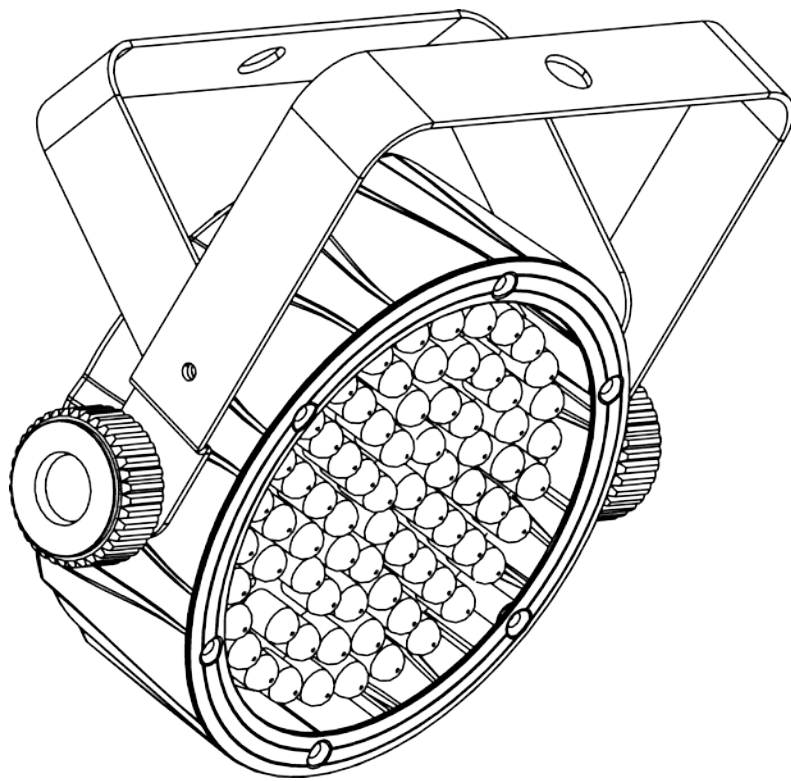

CHAUVET[®]
It's **Green** Thinking.[™]

TABLE OF CONTENTS

.....	1
1. BEFORE YOU BEGIN.....	3
WHAT IS INCLUDED.....	3
UNPACKING INSTRUCTIONS.....	3
MANUAL CONVENTIONS.....	3
ICONS.....	3
SAFETY INSTRUCTIONS.....	4
2. INTRODUCTION.....	5
CONTROL FEATURES.....	5
<i>Additional Features</i>	5
PRODUCT OVERVIEW.....	5
3. SETUP.....	6
AC POWER.....	6
POWER LINKING.....	6
MOUNTING.....	7
<i>Orientation</i>	7
<i>Rigging</i>	7
SIGNAL LINKING.....	8
4. OPERATING INSTRUCTIONS.....	9
<i>Control Panel Functions</i>	9
<i>Menu Map</i>	9
<i>Configuring the Starting Address</i>	10
<i>DMX Operation</i>	10
<i>Master/Slave (Standalone Operating Modes)</i>	10
STANDALONE OPERATION.....	11
<i>Automatic</i>	11
<i>Sound-Active</i>	11
<i>Preset Colors</i>	11
<i>Custom Static Colors</i>	11
DMX CHANNEL VALUES.....	12
<i>7-CH Mode</i>	12
<i>3-CH Mode</i>	12
5. APPENDIX.....	13
GENERAL TROUBLESHOOTING.....	13
GENERAL MAINTENANCE.....	13
RETURN PROCEDURE.....	14
CLAIMS.....	14
TECHNICAL SPECIFICATIONS.....	15
CONTACT US.....	16

1. BEFORE YOU BEGIN

What is Included

- 1 x SlimPAR™ 38
- 1 x Power Cord
- 1 x Warranty Card
- 1 x Quick Reference Guide

Unpacking Instructions

Immediately upon receiving a fixture, carefully unpack the carton, check the contents to ensure that all parts are present, and have been received in good condition. Notify the shipper immediately and retain packing material for inspection if any parts appear damaged from shipping or the carton itself shows signs of mishandling. Save the carton and all packing materials. In the event that a fixture must be returned to the factory, it is important that the fixture be returned in the original factory box and packing.



Manual Conventions

Chauvet manuals use the following conventions to differentiate certain types of information from the regular text.

CONVENTION	MEANING
[10]	A DIP switch to be configured
<Menu>	A key to be pressed on the fixture's control panel
1–512	A range of values
50/60	A set of values of which only one can be chosen
Settings	A menu option not to be modified (for example, showing the operating mode/current status)
MENU > Settings	A sequence of menu options to be followed
ON	A value to be entered or selected

Icons

This manual uses the following icons to indicate information that requires special attention on the part of the user.

ICONS	MEANING
	This paragraph contains critical installation, configuration or operation information. Failure to comply with this information may render the fixture partially or completely inoperative, cause damage to the fixture or cause harm to the user.
	This paragraph contains important installation or configuration information. Failure to comply with this information may prevent the fixture from functioning correctly.
	This paragraph reminds you of useful, although not critical, information.

Safety Instructions



Please read these instructions carefully. It includes important information about the installation, usage and maintenance of this product.

- Please keep this User Manual for future consultation. If you sell the unit to another user, be sure that they also receive this instruction booklet.
- Always make sure that you are connecting to the proper voltage, and that the line voltage you are connecting to is not higher than that stated on the decal or rear panel of the fixture.
- This product is intended for indoor use only! To prevent risk of fire or shock, do not expose fixture to rain or moisture.
- Make sure there are no flammable materials close to the unit while operating.
- The unit must be installed in a location with adequate ventilation, at least 20 in (50 cm) from adjacent surfaces. Be sure that no ventilation slots are blocked.
- Always disconnect from power source before servicing or replacing fuse and be sure to replace with same fuse source.
- Secure fixture to fastening device using a safety chain.
- Maximum ambient temperature (Ta) is 104 °F (40 °C). Do not operate fixture at temperatures higher than this.
- In the event of a serious operating problem, stop using the unit immediately. Never try to repair the unit by yourself. Repairs carried out by unskilled people can lead to damage or malfunction. Please contact the nearest authorized technical assistance center.
- Never connect the device to a dimmer pack.
- Make sure the power cord is never crimped or damaged.
- Never disconnect the power cord by pulling or tugging on the cord.
- Never carry the fixture directly from the cord. Always use the hanging/mounting bracket.
- Avoid direct eye exposure to the light source while it is on.
- To eliminate unnecessary wear and improve its lifespan, during periods of non-use completely disconnect the product from power via breaker or by unplugging it.

2. INTRODUCTION

Control Features

- 3 or 7-channel DMX-512 slim LED par can
- Operating modes:
 - 3-channel: RGB control
 - 7-channel: RGB, macros, run/strobe speed, automatic/sound, dimmer
- Static colors and RGB color mixing with or without DMX controller
- Built-in automated programs via master/slave or DMX with variable speed
- Built-in sound activated programs via master/slave or DMX
- Pulse effect with adjustable speed

Additional Features

- Low-profile lights are 2.5 in deep
- Power linking max: 50 units @ 120 VAC, 100 units @ 230 VAC
- Double-bracket yoke doubles as floor stand

Product Overview

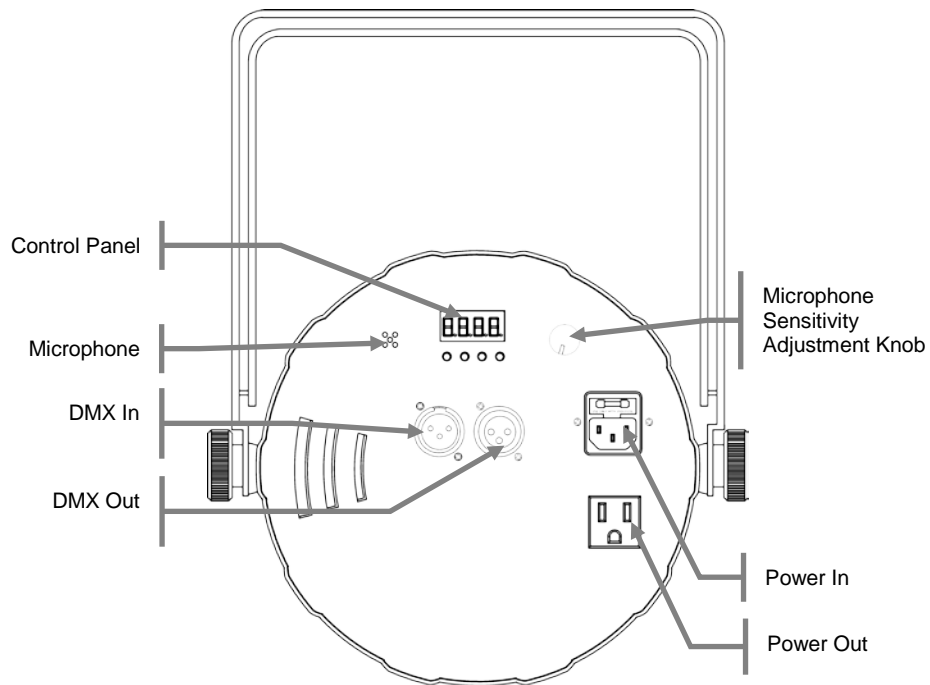

3. SETUP

AC Power

This fixture runs on 100–240 VAC, 50/60 Hz. Before powering on the unit, make sure the line voltage to which you are connecting it is within the range of accepted voltages.

To determine the power requirements for a particular fixture, see the label affixed to the back plate of the fixture or refer to the fixture's specifications chart. A fixture's listed current rating indicates its average current draw under normal conditions.



Always connect the fixture to a switched circuit. Never connect the fixture to a rheostat (variable resistor) or dimmer circuit, even if the rheostat or dimmer channel is used only as a 0 to 100% switch.



Always connect the fixture to a circuit with a suitable electrical ground.

Power Linking

This fixture contains power linking via the Edison outlet located on the back panel. Please see the diagram below for further explanation.



The maximum quantity of fixtures that may be linked is 50 at 120 V, or 100 at 230 V.

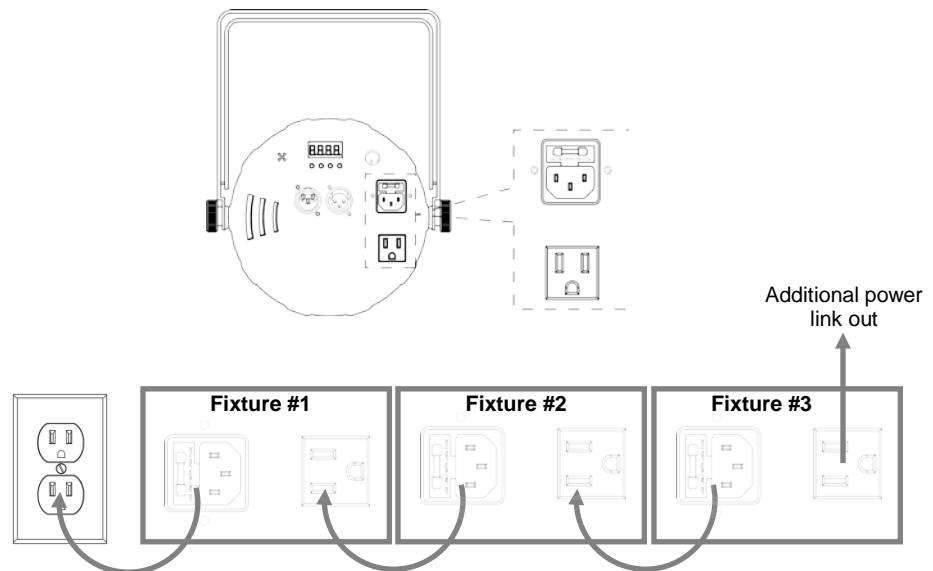

The power linking shown in this document is for the Chauvet North American version ONLY! Therefore, it is the customer's responsibility to check with the Dealer/Distributor regarding power linking on the local version of the product. Connections and availability may change, depending on the power requirements and/or regulations of each country/region.

Mounting

Orientation

The SlimPAR™ 38 may be mounted in any safe position.

Rigging

Be sure that the structure can support the weight of the fixture. Please see the “Technical Specifications” section of this manual for a detailed weight listing. Mount the fixture securely. This may be done with a screw, nut and bolt, or a hanging clamp. The hole in each bracket is 13 mm in size. When rigging consider routine maintenance and control panel access. Please see the following steps for installation.

- If the power link out is intended to be used with multiple fixture, take into account the length of each power cable, and mount the fixtures close enough to one another to accommodate for this.
- When aiming the fixtures, you may use the bracket adjustment knob. Loosen the knob, adjust to the desired angle, and then tighten the knob by turning clockwise. Do not use tools for this step, as it may cause damage.
- There is a secondary portion of the bracket, which may be used primarily for floor standing positions.
- Safety cables must always be used.

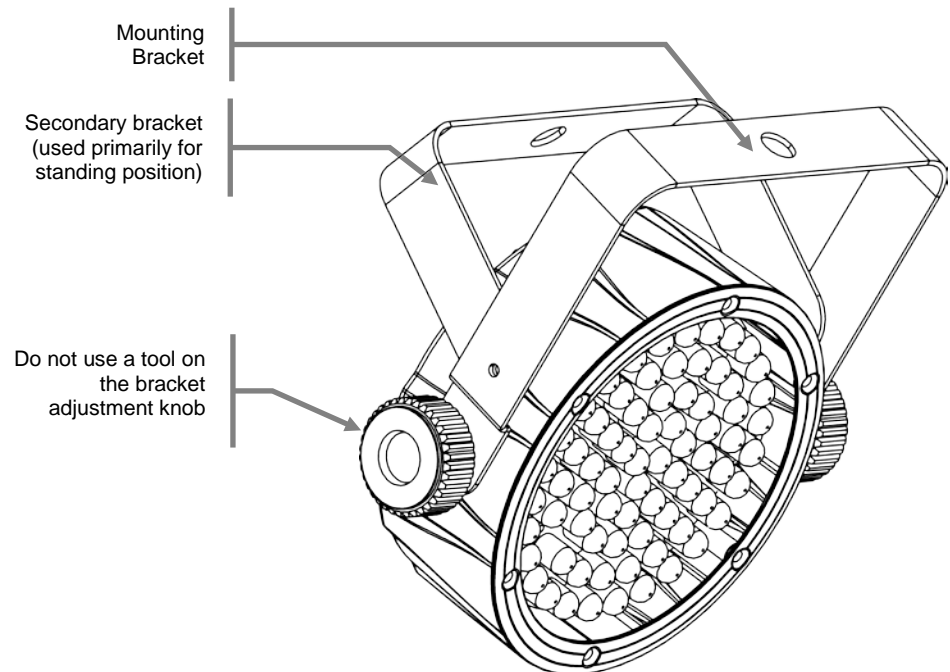

Signal Linking

In order to use this fixture in a DMX or master/slave operation, you must daisy chain, using DMX cables to link from one fixture to another.

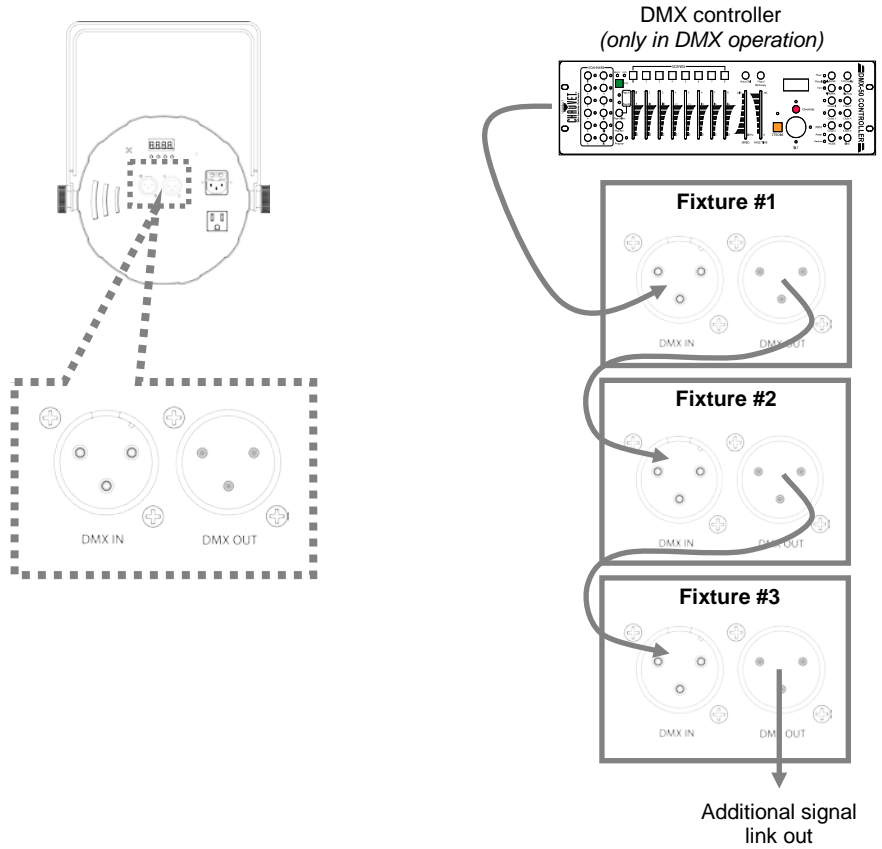

4. OPERATING INSTRUCTIONS

Control Panel Functions

Access control panel functions using the four buttons located directly underneath the LED display on the control panel.

BUTTON	FUNCTION
<MENU>	Used to scroll through the current operating mode, as well as back out of the current menu option
<UP>	Used to select increasing advancement in the value
<DOWN>	Used to select decreasing advancement in the value
<ENTER>	Used to select a value and store it to memory

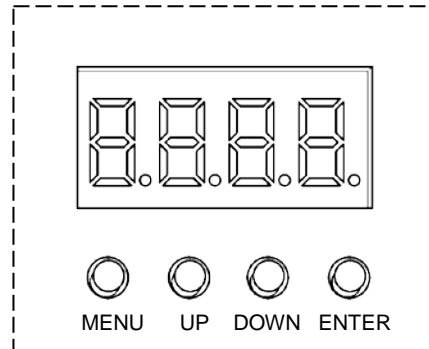

The Control Panel shows the current state of the unit. It is used to select the operating mode, as well as the sub-features. For a detailed layout of the control panel functions, please see the “menu map” section below.

Menu Map

MAIN FUNCTION	SUB-FUNCTION	SELECTION	SUB-SELECTION	INSTRUCTION
P--	P1	7 Color Switching		Select between 2 switching and 2 fading built-in programs
	P2	7 Color Fading		
	P3	3 Color Switching		
	P4	3 Color Fading		
	P5	7 Color sound active	<i>Use the Audio Adjustment Knob located on the back of the fixture</i>	Select between 2 sound active programs
	P6	3 Color sound active		
3-CH	d001–d512			Select 3-channel DMX mode (RGB control)
7-CH	d001–d512			Select 7-channel DMX mode: RGB, macros, run speed, strobe, automatic/sound, dimmer
C--	C1	Red		Select between 7 static colors. The display will read C1–C7. The colors that each of these represent are indicated to the left.
	C2	Green		
	C3	Blue		
	C4	Cyan		
	C5	Magenta		
	C6	Yellow		
	C7	White		
S--	S001–S100	(the default range is S050)		This is the speed range for the 4 switching and fading built-in programs
U--	r---	Red	000–100	Combine red, green, and blue to create a custom, static color
	g---	Green		
	B---	Blue		

Configuring the Starting Address

Each fixture requires a starting address from 1 to 512. A fixture requiring one or more channels for control begins to read the data on the channel indicated by the starting address. For example, a fixture that uses seven DMX channels and is addressed to start on DMX channel 100, will read data from channels: 100, 101, 102, 103, 104, 105 and 106. Choose the starting addresses for each fixture so that the channels used do not overlap. In addition, you should note the starting address selected for future reference.

The SlimPAR™ 38 uses **seven** or **three** DMX channels. If this is your first time using DMX, we recommend reading the “DMX Primer” section in the “Appendix”.

DMX Operation

This is the operating mode which will allow for control with an external DMX controller. You must set the starting address for this mode. If this is your first time using DMX, then it is recommended that you refer to the “DMX Primer” section in the “Appendix” of this manual.

1. Press <MENU> until **3-CH** or **7-CH** appears on the LED screen.
2. Press <ENTER>.
3. Using <UP> and <DOWN>, select the desired DMX address (**d001–d512**).

Master/Slave (Standalone Operating Modes)

This is the operating mode which will allow one fixture to act as the “master” and control all of the other “slave” fixtures. You must set both the master and the slave(s) fixtures to the correct mode for this operation.

Master Settings:

1. Connect the fixtures with DMX cables, as shown in the “Fixture Linking” section.
2. Use any one of the standalone modes for the master unit.
This includes: P--, C--, and U--

Slave Settings:

1. Press <MENU> until **3-CH** or **7-CH** appears on the LED screen.
2. Press <ENTER>.
3. Using <UP> and <DOWN>, set the DMX address to **d001**.
4. Press <ENTER>.



Although any fixture in the DMX daisy chain may be set to master, it is advisable to set the master as the first fixture in the line.



Only one fixture may be set to master.



Do not connect a DMX controller to the daisy chain for this operating mode.



It does not matter which DMX mode is selected for the slave fixtures. Either mode will be effective.

Standalone Operation

Automatic

This fixture has preprogrammed chases. These are accessed via the control panel. The speed may be adjusted for the chases. Please see the instructions below for further explanation.

1. Press **<MENU>** until **P--** appears on the LED screen.
2. Press **<ENTER>**.
3. Using **<UP>** and **<DOWN>**, select the desired program (**P1–P4**).
4. Press **<ENTER>**.
5. Press **<MENU>** until **S--** appears on the LED screen.
6. Using **<UP>** and **<DOWN>**, select the desired program speed (**S001—S100**).
7. Press **<ENTER>** to confirm settings.

Sound-Active

This fixture has preprogrammed sound triggered chases. These are accessed via the control panel. The microphone sensitivity may be adjusted using the audio adjustment knob. Please see the instructions below for further explanation.

1. Press **<MENU>** until **P--** appears on the LED screen.
2. Press **<ENTER>**.
3. Using **<UP>** and **<DOWN>**, select the desired program (**P5–P6**).
4. Press **<ENTER>** to confirm settings.

Preset Colors

This fixture has preprogrammed static color presets. These are accessed via the control panel. Please see the instructions below for further explanation.

1. Press **<MENU>** until **C--** appears on the LED screen.
2. Press **<ENTER>**.
3. Using **<UP>** and **<DOWN>**, select the desired color preset (**C1–C7**).
4. Press **<ENTER>** to confirm settings.

Custom Static Colors

This fixture has the ability to accept custom static color settings. These are accessed via the control panel. Please see the instructions below for further explanation.

1. Press **<MENU>** until **U--** appears on the LED screen.
2. Press **<ENTER>**.
3. Using **<UP>** and **<DOWN>**, select the desired color (**r, G, b**).
4. Press **<ENTER>**.
5. Using **<UP>** and **<DOWN>**, select the desired color value (**000–100**). By selecting **000**, the color will remain off.
6. Press **<ENTER>** to continue to the next color (**r, G, b**).
7. Using **<UP>** and **<DOWN>**, select the desired color value (**000–100**). By selecting **000**, the color will remain off.
8. Repeat steps 6 & 7 until the desired color is obtained. Press **<ENTER>** to save the final color setting. This will move the selection to the following color; however, this is necessary to save the modification.

The colors are represented by the following in the menu map:

r--- = Red (**000–100**)

G--- = Green (**000–100**)

b--- = Blue (**000–100**)

DMX Channel Values

7-CH Mode

CHANNEL	VALUE	FUNCTION
1	000 ó 255	Red Dimmer: 0–100%
2	000 ó 255	Green Dimmer: 0–100%
3	000 ó 255	Blue Dimmer: 0–100%
4	000 ó 015 016 ó 255	Color Macros (override CH.1–3) No Function Color Macros
5	000 ó 255	Speed (CH.6 @ values 32–223) Slow–Fast
	000 ó 015 016 ó 255	Strobe (RGB mode only) No Function Slow–Fast
6	000 ó 031 032 ó 063 064 ó 095 096 ó 127 128 ó 159 160 ó 191 192 ó 223 224 ó 255	Mode RGB mode Pulse effect 0–100% (using RGB faders) Pulse effect 100%–0 (using RGB faders) Pulse effect 100%–0–100% (using RGB faders) Auto fade transition Auto snap transition (3 colors) Auto snap transition (7 colors) Sound triggering mode
7	000 ó 255	Dimmer Intensity: 0–100% (RGB/Macro modes)

When CH.6 is set between 032–223, CH.5 controls the speed.

3-CH Mode

CHANNEL	VALUE	FUNCTION
1	000 ó 255	Red Dimmer: 0–100%
2	000 ó 255	Green Dimmer: 0–100%
3	000 ó 255	Blue Dimmer: 0–100%

5. APPENDIX

General Troubleshooting

SYMPTOM	POSSIBLE CAUSE(S)	POSSIBLE ACTION(S)
Breaker/Fuse keeps blowing	Excessive circuit load	Check total load placed on the electrical circuit.
	Short circuit along the power wires	Check for a short in the electrical wiring (internal and/or external).
Device does not power up	No power	Check for power on Mains.
	Loose power cord	Check power cord
Fixture is not responding to DMX	Wrong DMX addressing	Check Control Panel and unit addressing
	Damaged DMX cables	Check DMX cables
	Wrong polarity settings on the controller	Check polarity switch settings on the controller
	Loose DMX cables	Check cable connections
	Faulty DMX interface	Replace DMX input
Loss of signal	Faulty Main PCB	Replace Main PCB
	Non DMX cables	Use only DMX compatible cables
Loss of signal	Bouncing signals	Install terminator as suggested.
	Long cable / Low level signal	Install amplifier right after fixture with strong signal.
	Too many fixtures	Install an optically coupled DMX splitter after unit #32.
	Interference from AC wires	Keep DMX cables separated from power cables or black lights.



If you still have a problem after trying the above solutions, please contact Chauvet Technical Support.

General Maintenance

Dust build-up reduces light output performance and can cause overheating. This can lead to reduction of the light source's life. To maintain optimum performance and minimize wear, clean lighting products at least twice a month. However, be aware that usage and environmental conditions are contributing factors to increasing the cleaning frequency.

To clean the product, follow the instructions below:

1. Unplug the product from power.
2. Wait until the product is at room temperature.
3. Use a vacuum (or dry compressed air) and a soft brush to remove dust collected on the external surface/vents.
4. Clean all transparent surfaces with a mild soap solution, ammonia-free glass cleaner, or isopropyl alcohol.
5. Apply the solution directly to a soft, lint-free cotton cloth or a lens cleaning tissue.
6. Softly drag any dirt or grime to the outside of the transparent surface.

Gently polish the transparent surfaces until they are free of haze and lint.



Always dry the parts carefully after cleaning them.



Never spin a fan using compressed air.

Return Procedure

Returned merchandise must be sent prepaid and in the original packing; call tags will not be issued. Package must be clearly labeled with a Return Merchandize Authorization Number (RMA #). Products returned without the RMA # will be refused. Call Chauvet and request an RMA # prior to shipping the fixture. Be prepared to provide the model number, serial number and a brief description of the cause for the return. Be sure to pack fixture properly; any shipping damage resulting from inadequate packaging is the customer's responsibility. Chauvet reserves the right to use its own discretion to repair or replace product(s). FedEx packing or double-boxing are recommended.



If you are given an RMA #, please include the following information on a piece of paper inside the box:

- 1) ***Your name***
- 2) ***Your address***
- 3) ***Your phone number***
- 4) ***RMA #***
- 5) ***A brief description of the symptoms***

Claims

Damage incurred in shipping is the responsibility of the shipper; therefore, the damage must be reported to the carrier upon receipt of merchandise. It is the customer's responsibility to notify and submit claims with the shipper in the event that a fixture is damaged due to shipping. Any other claim for items such as missing component/part, damage not related to shipping, and concealed damage, must be made within seven (7) days of receiving merchandise.

TECHNICAL SPECIFICATIONS

WEIGHT & DIMENSIONS

Length..... 7.3 in (185 mm)
Width 8.1 in (206 mm)
Height 2.5 in (64 mm)
Weight 1.8 lbs (0.8 kg)

POWER

Auto-ranging power supply..... 100–240 VAC, 50/60 Hz
Power Consumption @ 120 V 9 W (0.1 A) max, 0.2 A inrush
Power Consumption @ 230 V 9 W (0.1 A) max, 0.2 A inrush
Power output..... 50 units max
Fuse F 1 A, 250 V

INDOOR/OUTDOOR

Rating For indoor use only

LIGHT SOURCE

LED 75 (25 red, 25 green, 25 blue)

PHOTOMETRICS

Lux @ 2 m 531
Beam angle..... 17°
Field angle 29°

THERMAL

Maximum ambient temperature..... 104° F (40° C)

ORDERING INFORMATION

SlimPAR™ 38..... SLIMPAR38

WARRANTY INFORMATION

Warranty 2-year limited warranty

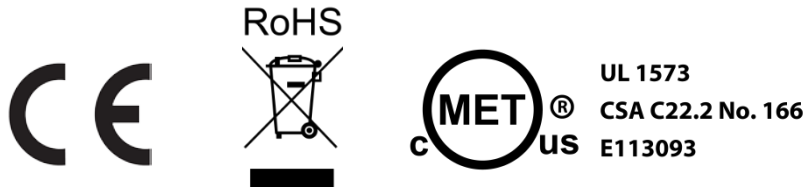

CONTACT Us

WORLD HEADQUARTERS - CHAUVET®

General Information

Address: 5200 NW 108th Avenue
Sunrise, FL 33351
Voice: (954) 577-4455
Fax: (954) 929-5560
Toll free: (800) 762-1084

Technical Support

Voice: (954) 577-4455 (Press 4)
Fax: (954) 756-8015
Email: tech@chauvetlighting.com

World Wide Web

www.chauvetlighting.com

UNITED KINGDOM AND IRELAND - CHAUVET® Europe Ltd.

General Information

Address: Unit 1C
Brookhill Road Industrial
Estate
Pinxton, Nottingham, UK
NG16 6NT
Voice: +44 (0)1773 511115
Fax: +44 (0)1773 511110

Technical Support

Email: uktech@chauvetlighting.com

World Wide Web

www.chauvetlighting.co.uk

MEXICO - CHAUVET® Mexico

General Information

Address: Av. Santa Ana 30
Parque Industrial Lerma
Lerma, Mexico C.P. 52000
Voice: +52 (728) 285-5000

Technical Support

Email: servicio@chauvet.com.mx

World Wide Web

www.chauvet.com.mx

Outside the U.S., United Kingdom, Ireland, or Mexico, contact your dealer. Follow their instructions to request support or to return a product. Visit our website for contact details.